

NOTES:  
 1. ASSURE ASSEMBLY CAPABILITY BY MATCHING WITH MATING PART

REVISION HISTORY		CHANGED BY	CHANGE DATE	APPROVED BY	APPROVED DATE
REV.	DESCRIPTION				
A1	PRODUCTION RELEASE				

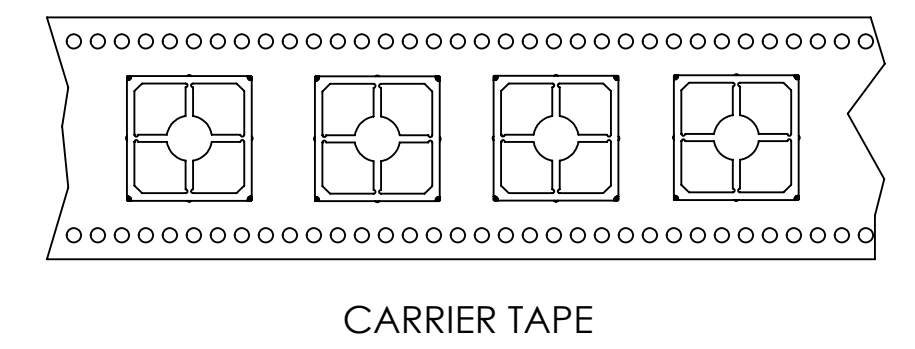

CARRIER TAPE SPECIFICATIONS						
PART NUMBER	DESCRIPTION	OVERALL DIMENSIONS	OVERALL HEIGHT	CARRIER TAPE WIDTH	CARRIER TAPE PITCH	PARTS PER REEL
SMS-402F	FRAME	.650 X .650 [16.51 X 16.51]	.142 [3.60]	32 mm	24 mm	700
SMS-402C	COVER	.672 X .672 [17.07 X 17.07]	.079 [2.01]	N/A	N/A	BULK PACK

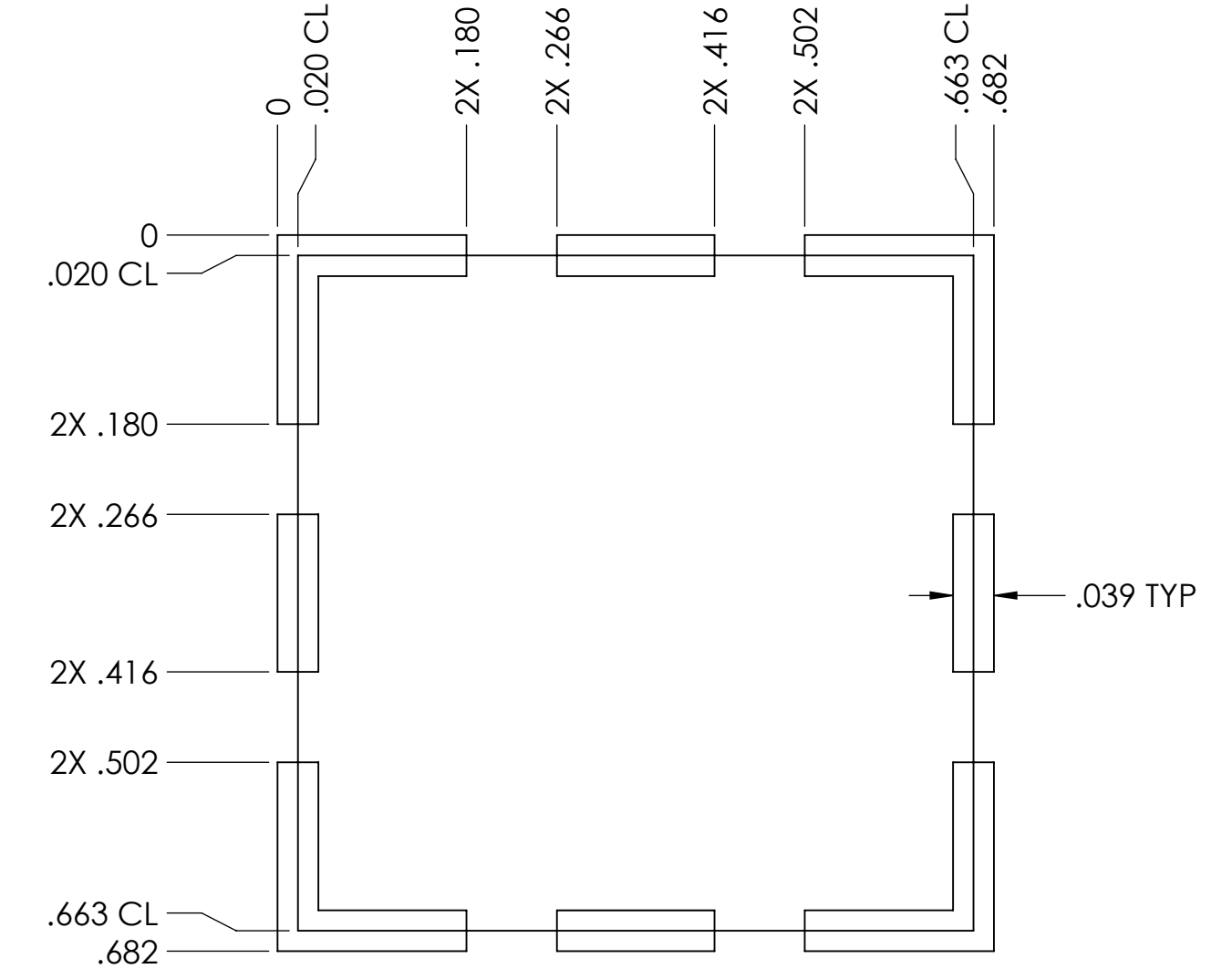
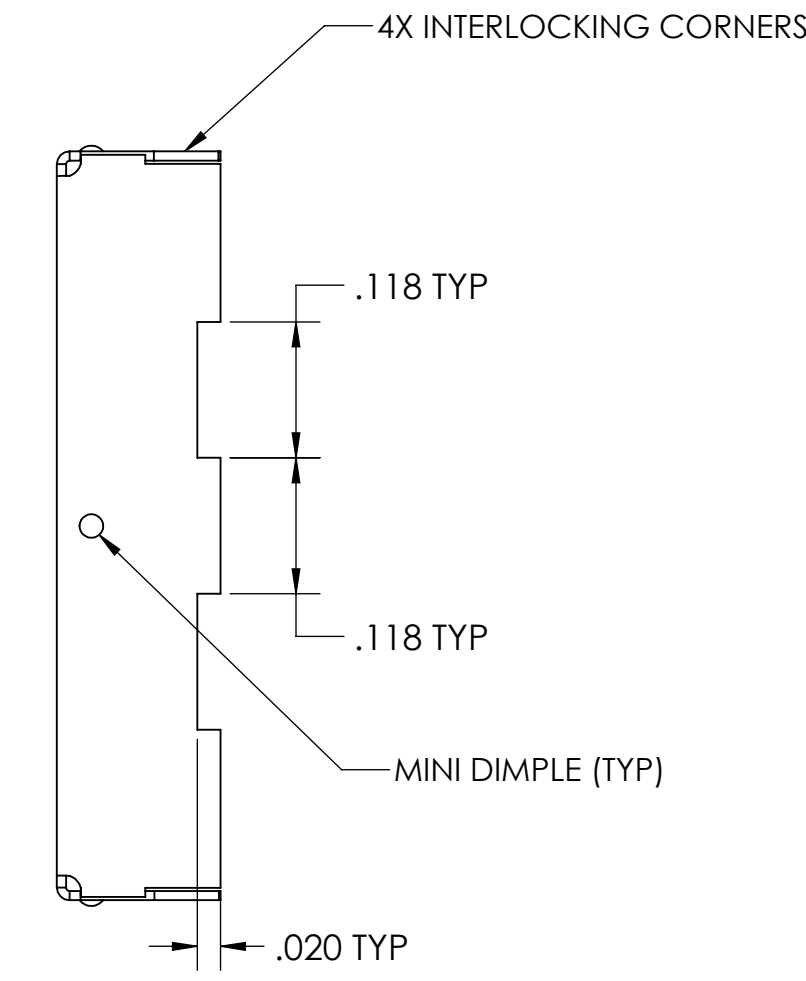
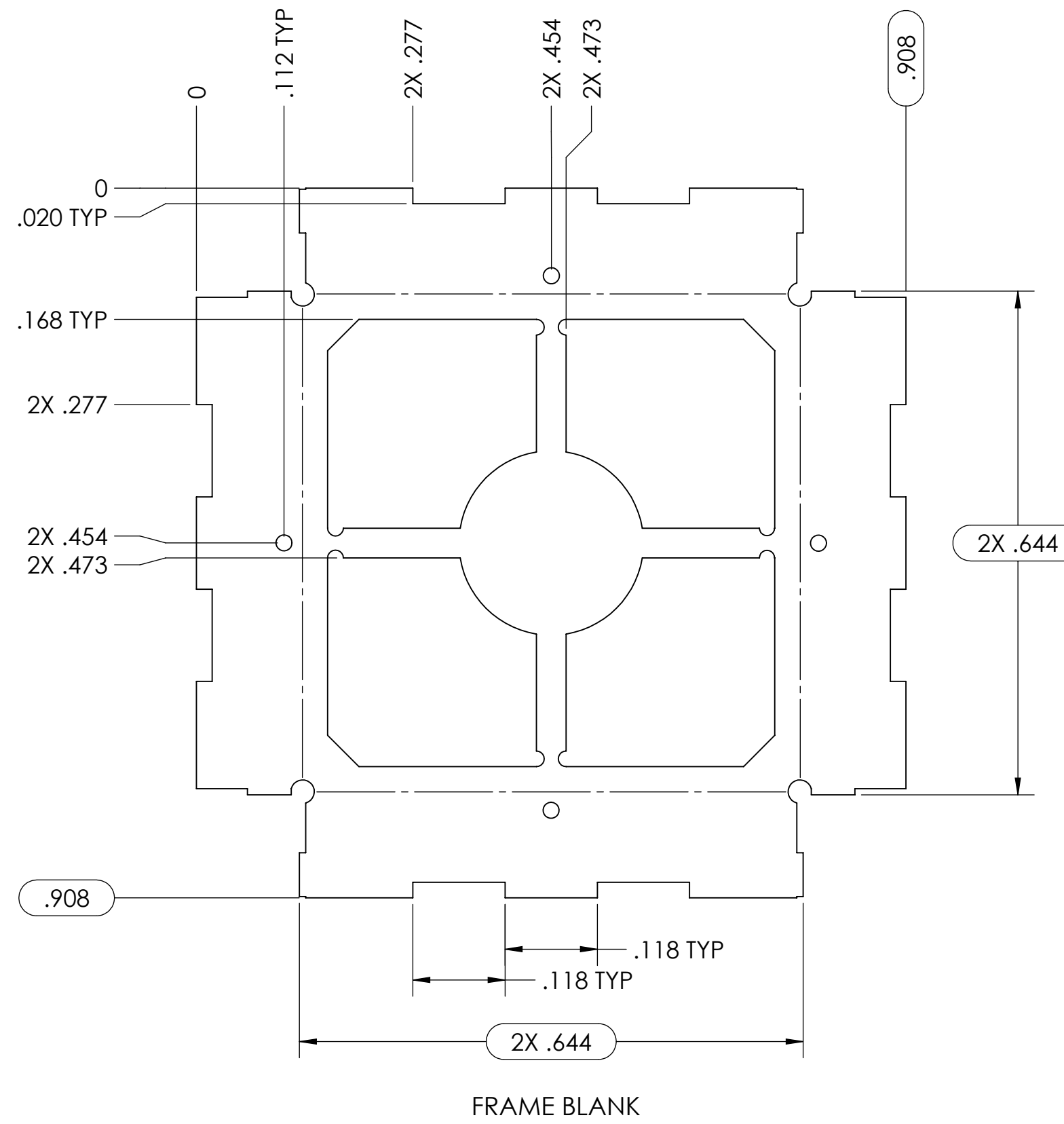
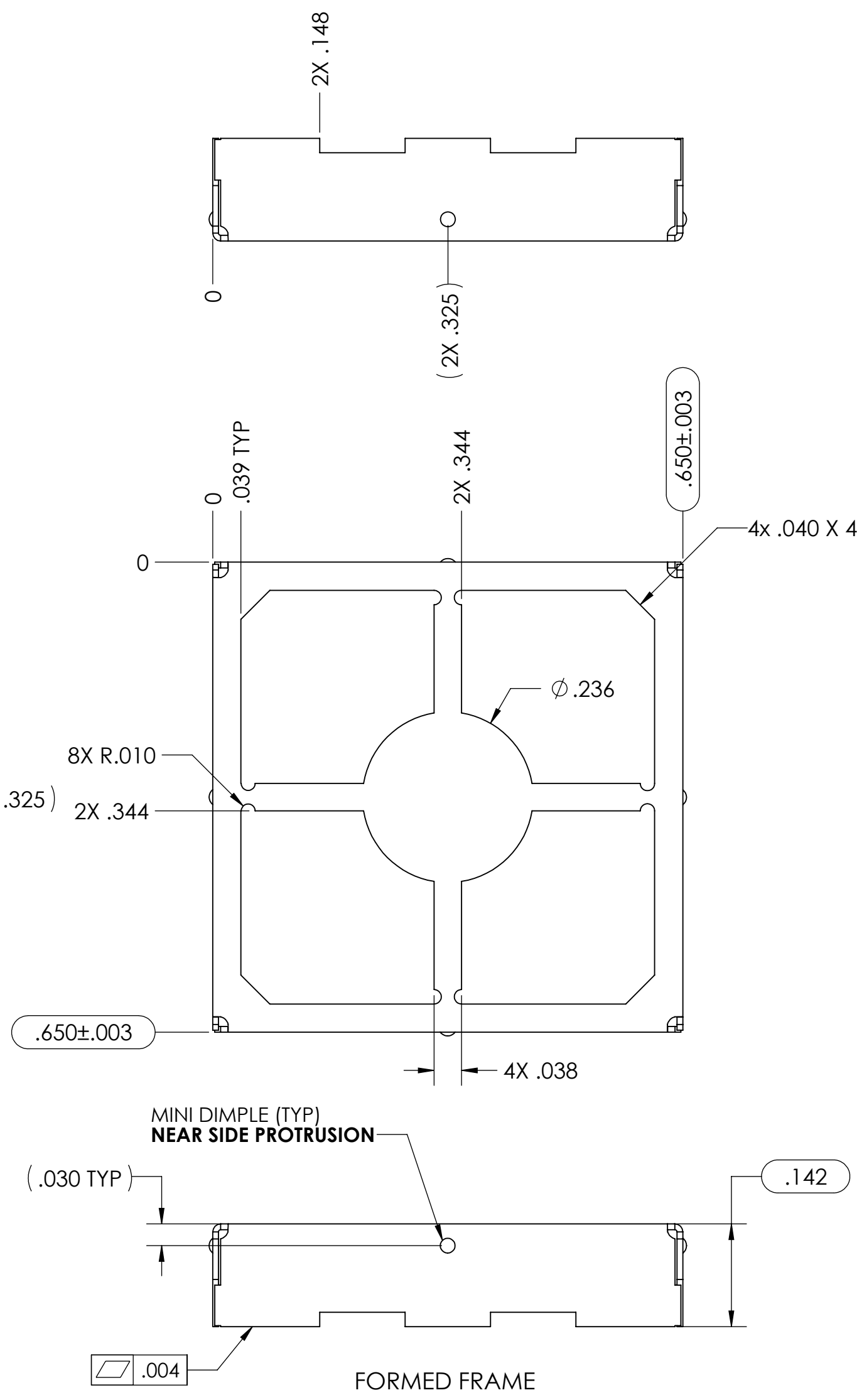
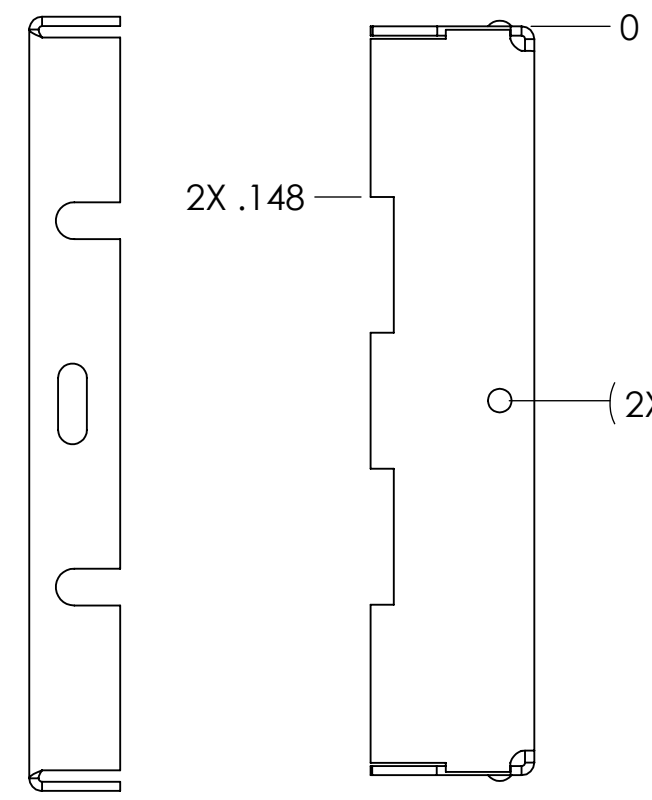
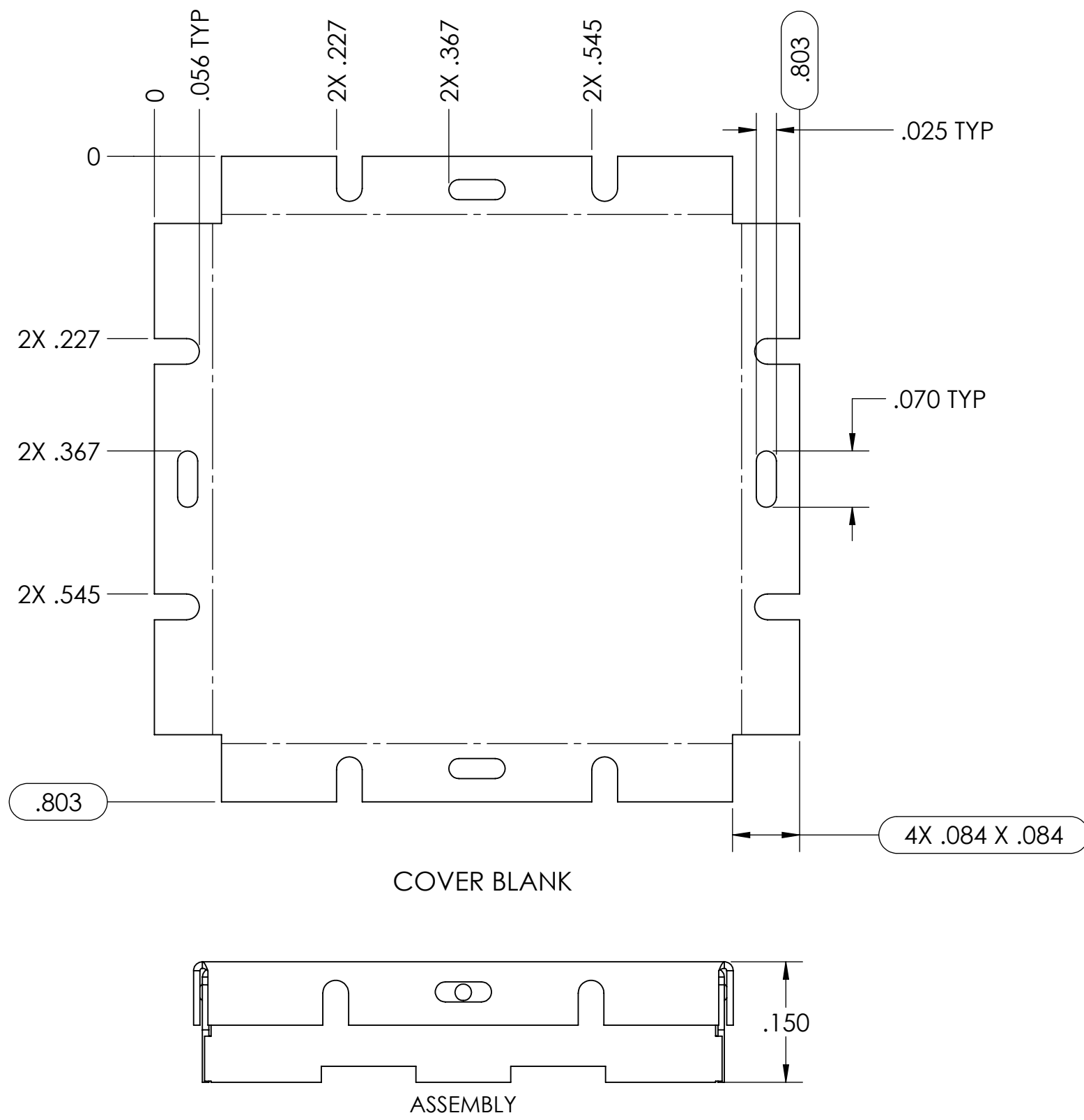
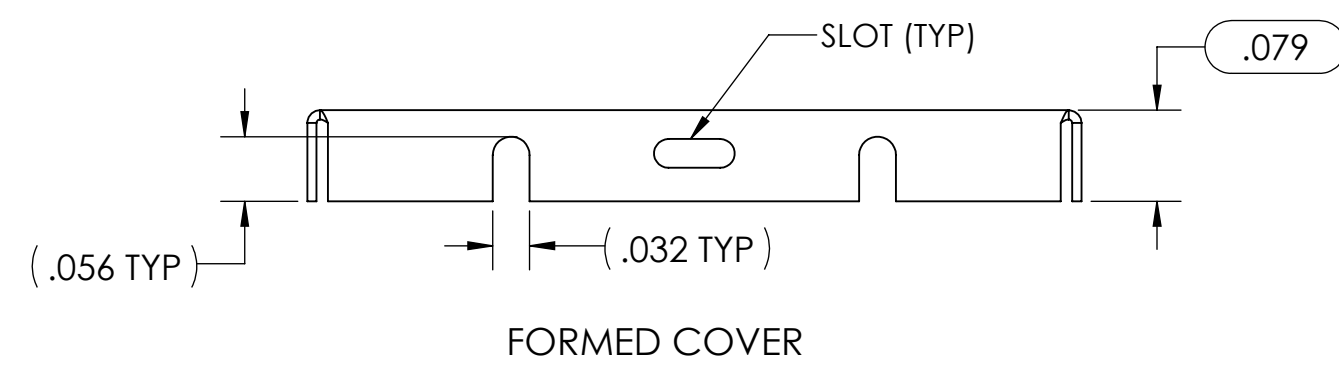
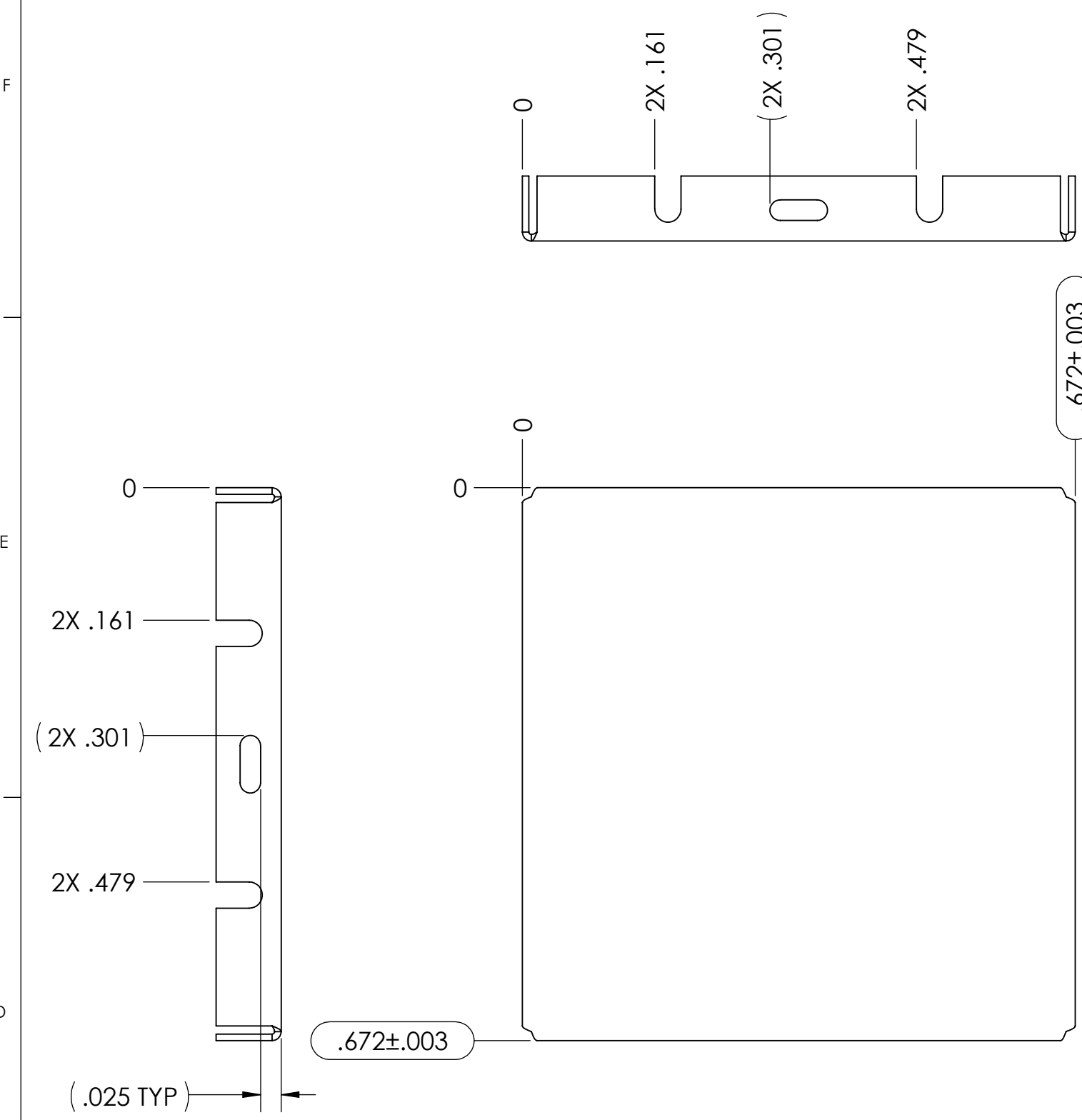
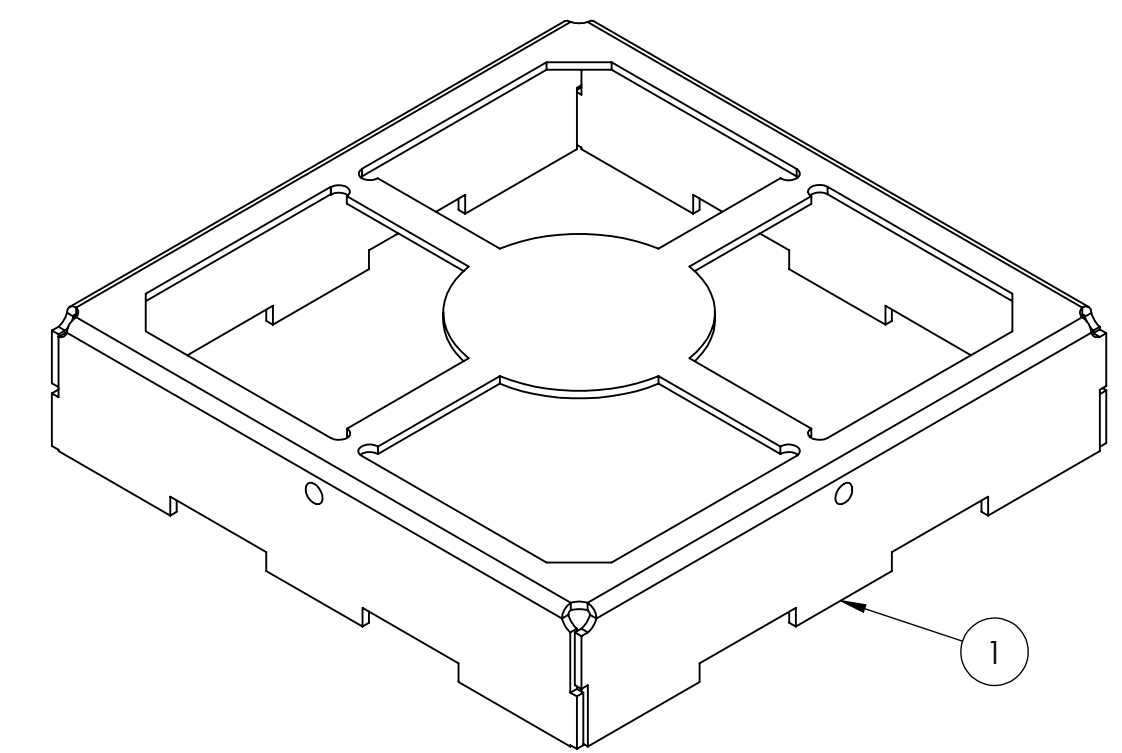
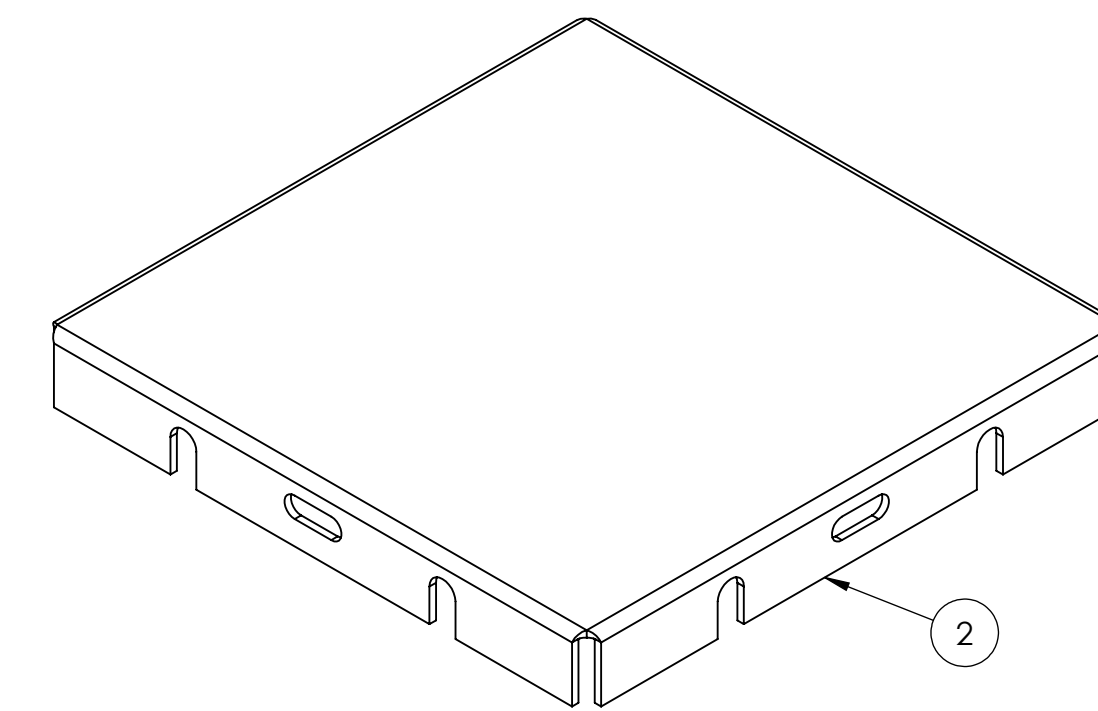

ITEM NO.	PART NUMBER	DESCRIPTION	QTY.
1	SMS-402F	FRAME	1
2	SMS-402C	COVER	1

UNLESS OTHERWISE SPECIFIED:  
 - ALL DIMENSIONS ARE IN INCHES  
 - PART SHALL BE FREE OF BURRS AND SHARP EDGES  
 - ALL DIMENSIONS SHOWN APPLY AFTER PLATING AND COATINGS  
 - ROHS COMPLIANT PER EU DIRECTIVE 2011/65/EU  
 - POI = POINT OF INTERSECTION

THIRD ANGLE PROJECTION

ANGLES +/- 2°

SCALE: 6:1

DATE: 2015-04-16

DRAWN BY: ACS

APPROVED BY:

MATERIAL: MATTE .008" PRE TIN STEEL

LEADER TECH  
 a HEICO company  
 The Leading Edge in PAM Manufacturing Technology

TITLE: SURFACE MOUNT SHIELD

SIZE: D

DWG. NO.: SMS-402-MFG

REV: A1

CAGE CODE: 41674

SHEET: 1 OF 1

THIS DOCUMENT CONTAINS PROPRIETARY INFORMATION OWNED BY LEADERTECH OR DEVELOPED AT ITS OWN PRIVATE EXPENSE AND MAY NOT BE USED, DUPLICATED OR DISCLOSED IN WHOLE OR IN PART FOR ANY PURPOSE INCLUDING DESIGN, MANUFACTURE OR PROCUREMENT WITHOUT THE WRITTEN PERMISSION OF LEADERTECH. LEADERTECH DOES NOT GUARANTEE OR WARRANT THE PERFORMANCE CHARACTERISTICS.